RF POWER AMPLIFIER

MODEL A041

P/N 1200-10-10-40-R

Serial Number XX

10 TO 1200 MHz

10 WATTS

TABLE OF CONTENTS

1. INTRODUCTION 2

2. GENERAL DESCRIPTION 2

 2.1 Purpose 2

 2.2 Description 2

3. SPECIFICATIONS 3

4. TEST DATA 3

5. AMPLIFIER MECHANICAL OUTLINE 7

6. AMPLIFIER INSTALLATION 7

7. AMPLIFIER OPERATION 7

 7.1 Description of Controls and Indicators 7

 7.2 OPERATING PROCEDURE 10

 7.2.1 Turn On Sequence 10

 7.2.2 Pre-operation test set up. 11

8. THEORY OF OPERATION 12

 8.1 Introduction. 12

 8.2 Description. 13

9. MAINTENANCE AND TROUBLE SHOOTING 14

 9.1 Introduction 14

 9.2 Routine Maintenance & Inspection 14

 9.2.1 Cleaning 14

 9.2.2 Routine Inspection 15

10. REPLACEABLE PARTS 15

11. REPAIR 16

12. WARRANTY 16

1. INTRODUCTION

This manual provides information on LCF Enterprises ANALOG RF HIGH POWER AMPLIFIER MODEL A041 and Part Number 1200-10-10-40-R. Specifically a description of the amplifier system, its specifications, test data, operation, maintenance and repair.

2. GENERAL DESCRIPTION

2.1 Purpose

The amplifier system is designed for use anywhere where amplification of RF signals is required. Typical applications include communication systems, general laboratory testing, antenna and component testing, calibration, EMI susceptibility testing, EMC testing and MRI studies. The amplifier system is broadband and operates from 10 MHz to 1200 MHz with 10 watts typical continuous output power.

2.2 Description

The solid-state amplifier system is self-contained and includes the power supply, cooling, protection features, indicators and monitors. All controls and performance monitoring are located on the front panel of a 19-inch rack-mount cabinet. The input signal is fed into the connector marked "RF IN" and the amplifier output signal is taken from the connector marked "RF OUT". Forced cooling is provided with self-contained fans. The unit is turned on by activating the power switch.

3. SPECIFICATIONS

Frequency Range:	10 to 1200 MHz
RF Output Power:	10 watts cw minimum
Gain:	40 dB typical
Connectors:	Type N female
Cooling:	Air cooled

4. TEST DATA

See attached test data report on P/N 1200-10-10-40-R for Serial Number xx.

5. AMPLIFIER MECHANICAL OUTLINE

A detailed mechanical drawing of Model A041 is provided in Figure 1.

6. AMPLIFIER INSTALLATION

The amplifier system is designed for mounting in a standard 19-inch equipment rack or it can stand alone on a bench top. For mounting proceed as follows;

- i) For an equipment rack, secure the amplifier to the rack with four screws through the slotted holes on the front panel.
- ii) For mounting on a bench top, have a secure and clean area on the bench.

BE SURE TO CHECK FAN GUARD IS CLEAR OF FAN BEFORE USE. FAN SHOULD BE CLEAR OF FAN GUARD DURING OPERATION OR UNIT WILL OVERHEAT

7. AMPLIFIER OPERATION

Figure 2 shows the Model A041 P/N 1200-10-10-40-R front panel in pictorial form.

7.1 Description of Controls and Indicators

Power:	A red LED lamp that lights indicating that power is on.
Thermal Overload:	A red LED lamp that lights when a fault or over temperature condition is sensed in the amplifier.
Over Current:	A red LED lamp that lights when an over current condition is sensed on the amplifier. A buzzer is activated under this condition.
Power Switch:	ON/OFF Power switch for the amplifier.
Current (Amps) Display:	A digital display that indicates the total current consumed by the amplifier.

ij

Figure 1.Use cad file 033rack.dwg

hhh

Figure 2.use cad file fprack2.dwg

RF IN:	A Type N female connector that accepts a customers RF input signal.
RF OUT:	A Type N female connector that supplies the RF output signal.
Blanking (Option):	Not applicable.

7.2 OPERATING PROCEDURE

7.2.1 Turn On Sequence:

1. Connect input signal to RF IN connector. Recommend first using small signal input (i.e. -32 dBm).
2. Connect load to RF OUT connector.
3. Activate power switch to ON position. A red indicator light (LED) labeled POWER will light up when power is applied.
4. Maintain an RF input frequency of 10 to 1200 **MHz**.

NOTES:

1. The amplifier has automatic current limiting. A current limiting condition may arise when operating into a short or bad load. The system will not shut down under current limiting conditions and will continue to operate and automatically and transparently recover. The current can be observed on the current meter on the front panel. Additionally, a **buzzer** will sound when a current limiting condition exist (>2.7 - 3.0 AMPS).
2. Electrical fuse protection is also provided to protect the amplifier module in the event the system is over driven by a fast pulse which exceeds the response time of the automatic current limiting.

3. Should the amplifier system experience an over temperature condition, the THERMAL OVERLOAD LED will light up on the front panel. The amplifier system will not operate under this condition. Likely causes include blockage of the air intake or the fan. The light is activated at temperatures of 60 °C. The thermal switches are self resetting when the temperature conditions stabilize, and amplifier system operations will continue.
4. **WARNING: DO NOT TURN DC POWER ON & OFF WHILE RF DRIVE IS ON.**

7.2.2 Pre-operation test set up.

- a. Connect the amplifier system as illustrated in the test set up in Figure 3.
- b. Activate power switch to ON position. A red indicator light (LED) labeled POWER will light up when power is applied. Verify all cooling fans are operating.
- c. Set the signal generator output to -32.0 dBm and its frequency of 10 MHz. Step up the input signal slowly until the output power reaches 10 watts. Monitor the current value.
- d. Verify that the power meter in the test set up indicates the correct value listed on the test data sheet.
- e. Verify that the current meter on the front panel of the amplifier system indicates the correct value listed in the test data sheet for the selected frequency.
- f. When test is completed, turn off all power and disconnect all test equipment.

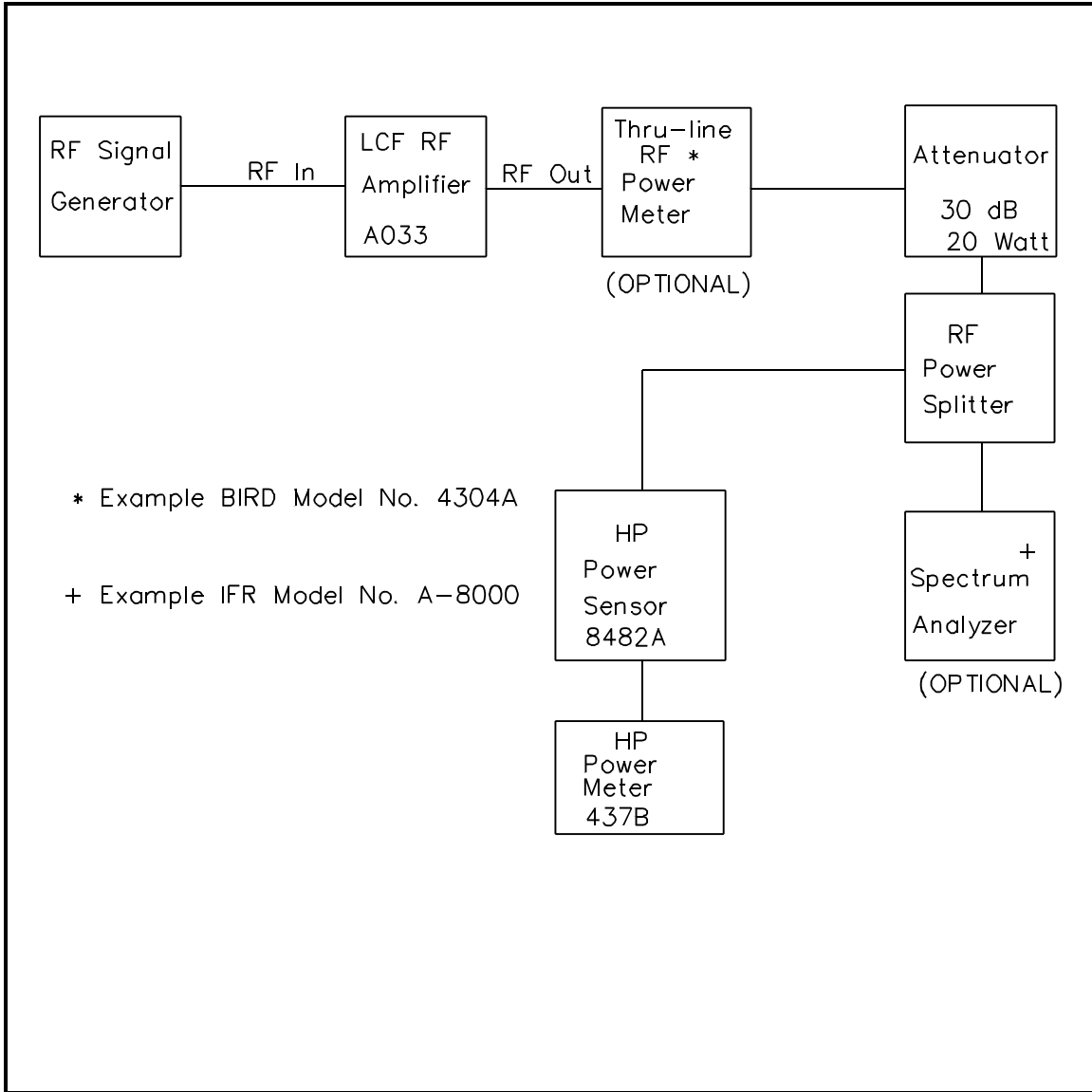

Figure 3. Amplifier pre-operation test set up.

8. THEORY OF OPERATION

8.1 Introduction.

This section contains information on the theory of operation of the Model A041 amplifier system. The amplifier system consists of a pre amplifier, amplifier module, power supply, cooling, protection features, indicators and controls. A block diagram of the system is illustrated in Figure 4. The amplifier system is designed for Class AB linear operation and provides an instantaneous frequency of 10 to 1200 MHz with 10 watts typical CW output power.

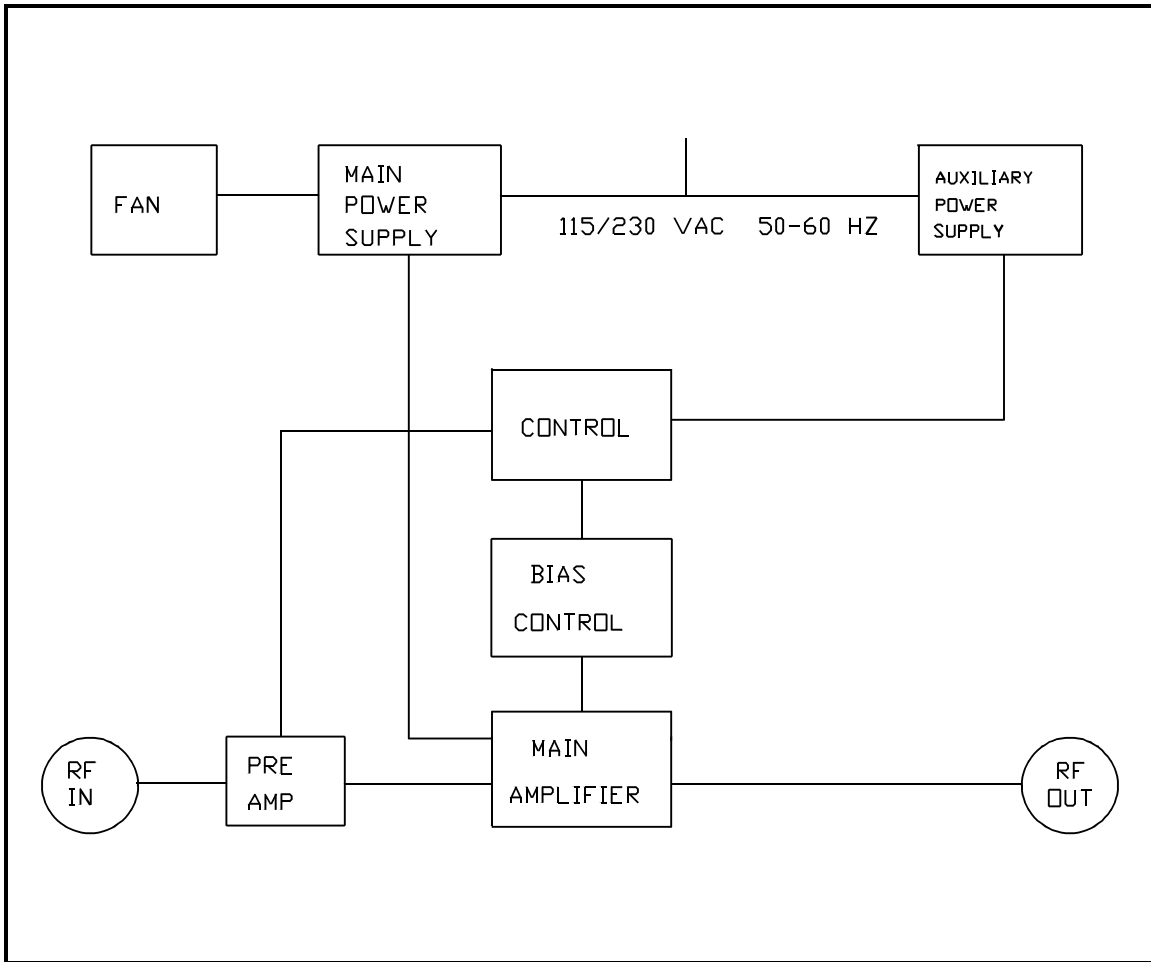

Figure 4. Amplifier system block diagram.

8.2 Description.

RF signals to be amplified enter the amplifier system through the RF IN connector on the front panel (see Figure 2). The pre amplifier and power amplifier module increase the gain of the signal to a power level of 10 watts. This output power is available at the RF OUT connector on the front panel for application to the user's output load.

Amplifier system prime power is provided through the rear panel cord (120 VAC/60 Hz). Verify red switch on back panel is set to 120 VAC. The systems internal power supply provides the required operating potentials to power the amplifier module. The operating current is monitored on the meter on the front panel.

9. MAINTENANCE AND TROUBLE SHOOTING

9.1 Introduction

The amplifier system should require very little maintenance. It is built with solid state devices which should ensure a long, trouble-free life. However, should trouble occur special care must be taking in servicing to avoid damage to the devices.

LCF Enterprises amplifier is conservatively rated to provide high reliability. If, however, a part within the amplifier system fails, the system should be repaired immediately. Due to the importance of the amplifier's alignment, it is highly recommended that the amplifier be returned to the factory for part replacement and amplifier realignment. Please advise the factory directly to coordinate the repair and shipment method.

9.2 Routine Maintenance & Inspection

WARNING

REMOVE ALL POWER TO THE AMPLIFIER SYSTEM WHEN ATTEMPTING TO PERFORM ANY INSPECTION. UNPLUG THE POWER CORD.

WARNING

DO NOT TURN DC POWER ON & OFF WHILE RF DRIVE IS ON!! THIS WILL DAMAGE THE AMPLIFIER

9.2.1 Cleaning

The customer should periodically perform an inspection and cleaning for preventive maintenance. The exterior should be periodically cleaned with a clean cloth to remove any build up of dirt and dust.

9.2.2 Routine Inspection

<u>Inspection Point</u>	<u>Possible Cause</u>
Cables	Damaged or deteriorated insulation. Loose or damaged connectors.
Wiring	Frayed, broken or damaged insulation. Broken or loose leads.
Digital Display	Cracked meter or window face. Loose connections
Indicators and Lamps	Loose mounting. Missing or broken lamps.
Panels	Loose or missing parts. Illegible marking or physical damage.

10. REPLACEABLE PARTS

To replace fuses on the inside, remove top cover by removing eight screws on top. The main amplifier module has a mother board on each side. Each mother board has a single fuse on it. Note that if the LED light next to the fuses on the mother board is on, then the fuse is good. If however, the LED light is not on, then the fuse needs to be replaced. The fuse values are each type GMA (i.e.2 Amps and 5 mm x 20 mm - fast blow).

There are an additional two fuses in the yellow in-line fuse holders for the smaller power supply and those are 0.5 Amp AGC - fast blow fuses.

On the front panel, on the outside of the amplifier system, there is one fuse location. For 230 VAC/50 Hz operation, both fuses are used. The values are listed below,

Table I. Front panel fusing.

<u>VOLTAGE SWITCH*</u>	<u>EXT.FUSE CURRENT</u>	<u>FUSE TYPE</u>	<u>QUANTITY</u>
120 VAC	4 AMPS	AGC4	1
220 VAC	2 AMPS	GMA3	2

*Voltage selection switch located on rear panel.

11. REPAIR

Repair of the amplifier system by the customer is limited to replacing the fuses. Any breakdown or abnormal behavior should be reported to the factory. The factory will then make a determination if the amplifier system should be returned and if so provide the customer with an authorization number and shipping instructions.

12. WARRANTY

MODEL A041 RACK-MOUNT SYSTEMS

P/N 1200-10-10-40-R

LCF Enterprises warrants products to the original purchaser of its manufacture to be free from defects in material and workmanship under conditions of normal use. LCF Enterprises at its option and expense will replace or repair any defective or faulty product which results directly from defects in material or workmanship provided, however, that LCF first be given written notice of such defects and shall have authorized the return. Items claimed defective must be returned to LCF and all transportation charges prepaid. The existence of a defect or fault shall be determined by LCF and its determination shall be conclusive. This warranty is limited to a period of 12 months after invoice date. LCF at its option, and at no charge to the buyer, will repair or replace any returned parts which are determined to be defective within the warranty period. This warranty does not apply

to products which have been disassembled, modified, physically or electrically damaged, or subjected to conditions exceeding the applicable specifications ratings. A fee will be charged to the buyer to cover testing and processing costs for units returned and subsequently found to have no defects or to be faulty for reasons which are not LCF's responsibility.

This warranty is the extent of the obligation or liability assumed by LCF Enterprises with respect to its products and no other warranty or guarantee is either expressed or implied. In no event does LCF Enterprises assume liability for installation or for consequential damages.